

# EMN-2RS

Data sheet - rev. 1.0

## Rod Ends - Classic Line

Rod ends with pressed spherical-plain bearing, with -2RS lip seals on both sides, male thread, series E/EH, DIN ISO 12240-4, maintenance required

## FEATURES AND ADVANTAGES

- **HOUSING:** C45 forged steel, tempered, surface galvanized, free of Cr VI
- **OUTER RING:** ball bearing steel, hardened, ground, phosphated, from size 15 with single split, oil groove and drill holes; with -2RS lip seals on both sides
- **JOINT BALL:** 100Cr6 ball bearing steel, hardened, ground, phosphated
- **MAINTENANCE:** maintenance required, oiled on delivery, initial lubrication by the user
- **GREASE NIPPLE:** DIN 3405 D1/A (sizes 15 to 17), DIN 71 412 H1 (sizes 20 to 70)
- **TEMPERATURE RANGE:** -40° C to +120° C
- **USE & MAINTENANCE :** [see this page](#)
- **STATIC LOAD SERVICE LIFE :** [see this page](#)
- **TOLERANCES :** [see this page](#)

## COMPONENTS AND DIMENSIONS

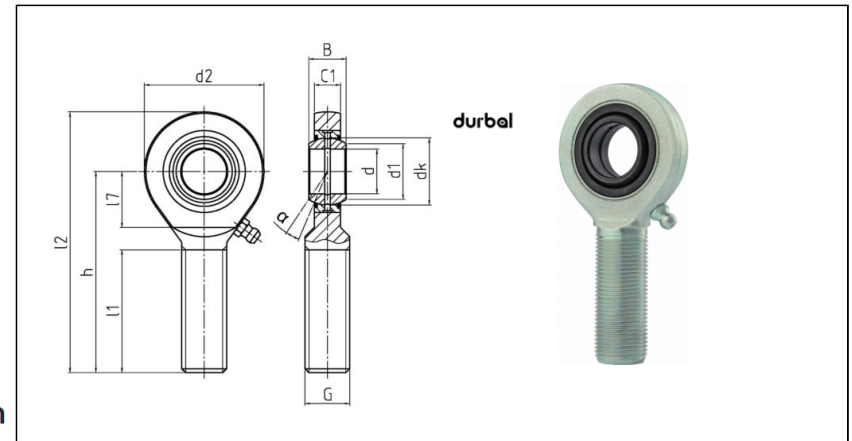

Type		Measurements [mm]															Tilt angle	Rotational speed limit	Axial factor	Basic load rating		Radial clearance	Weight	
Right hand thread	Left hand thread	d	G	B	C1	h/h1	d1	d2	d3	d4	dk	l1/l3	l2/l4	l5	l7	W	$\alpha$ (°)	$n_{max}$ (min <sup>-1</sup> )	Y	Y0	dyn C (kN)	stat C0 (kN)	CN (µm)	kg
EMN 15 - 30 - 501	EMN 15 - 30 - 502	15	M14	12	9	63	18	38	-	-	22	36	82	-	18	-	8	-	-	-	13.4	35.2	40-82	0.14
EMN 17 - 30 - 501	EMN 17 - 30 - 502	17	M16	14	10	69	20	44	-	-	25	40	91	-	23	-	10	-	-	-	19.2	38.1	40-82	0.19
EMN 20 - 30 - 501	EMN 20 - 30 - 502	20	M20x1.5	16	12	78	24	51	-	-	29	47	103.5	-	25	-	10	-	-	-	25.2	52.2	40-82	0.31
EMN 25 - 30 - 501	EMN 25 - 30 - 502	25	M24x2	20	16	94	29	62	-	-	35.5	57	125	-	32	-	9	-	-	-	42.4	86.5	30-100	0.56
EMN 30 - 30 - 501	EMN 30 - 30 - 502	30	M30x2	22	18	110	34	70	-	-	40.7	66	145	-	35	-	7	-	-	-	54	112	30-100	0.89
EMN 35 - 30 - 501	EMN 35 - 30 - 502	35	M36x3	25	20	140	39	82	-	-	47	92	181	-	38	-	6	-	-	-	70.4	146.6	30-100	1.4
EMN 40 - 31 - 501	EMN 40 - 31 - 502	40	M39x3	28	22	150	45	92	-	-	53	99	196	-	42	-	7	-	-	-	86	179.4	40-120	1.72
EMN 40 - 30 - 501	EMN 40 - 30 - 502	40	M42x3	28	22	145	45	92	-	-	53	94	191	-	42	-	7	-	-	-	86	179.4	40-120	1.8
EMN 45 - 30 - 501	EMN 45 - 30 - 502	45	M45x3	32	25	165	50	102	-	-	60	100	216	-	50	-	7	-	-	-	107	230.8	40-120	2.6
EMN 45 - 31 - 501	EMN 45 - 31 - 502	45	M42x3	32	25	163	50	102	-	-	60	98	214	-	50	-	7	-	-	-	107	230.8	40-120	2.5
EMN 50 - 30 - 501	EMN 50 - 30 - 502	50	M52x3	35	28	195	55	112	-	-	66	120	251	-	60	-	6	-	-	-	132	280.8	40-120	3.4
EMN 50 - 31 - 501	EMN 50 - 31 - 502	50	M45x3	35	28	185	55	112	-	-	66	110	241	-	60	-	6	-	-	-	132	280.8	40-120	3.28
EMN 60 - 30 - 501	EMN 60 - 30 - 502	60	M60x4	44	36	225	66	135	-	-	80	140	292.5	-	70	-	6	-	-	-	208	437.3	40-120	5.9
EMN 60 - 31 - 501	EMN 60 - 31 - 502	60	M52x3	44	36	210	66	135	-	-	80	125	277.5	-	70	-	6	-	-	-	208	437.3	40-120	5.76
EMN 70 - 31 - 501	EMN 70 - 31 - 502	70	M56x4	49	40	235	77	162	-	-	92	130	316	-	88	-	6	-	-	-	315	619.8	72-142	9
EMN 70 - 30 - 501	EMN 70 - 30 - 502	70	M72x4	49	40	265	77	162	-	-	92	140	346	-	88	-	6	-	-	-	315	619.8	72-142	11.75