

BRM

Data sheet - rev. 1.0

Rod Ends - Premium Line

Rod ends with ball bearing, male thread, series K, DIN ISO 12240-4, low maintenance, lubrication possible

FEATURES AND ADVANTAGES

- **HOUSING:** 17Cr3 forged steel, case hardened bearing race, superfinished, surface galvanized, free of Cr VI
- **INNER RING:** 100Cr6 ball bearing steel, hardened, superfinished
- **ROLLING ELEMENT:** 100Cr6 ball bearing steel, hardened, superfinished
- **MAINTENANCE:** low maintenance, lubrication possible, aluminium-complex-soap-grease, approval according to USDA H1
- **GREASE NIPPLE:** DIN 3405 D1/A (until size 10) / DIN 71 412 H1 (from size 12)
- **TEMPERATURE RANGE:** -45° C to +120° C
- **USE & MAINTENANCE :** [see this page](#)
- **STATIC LOAD SERVICE LIFE :** [see this page](#)
- **TOLERANCES :** [see this page](#)

COMPONENTS AND DIMENSIONS

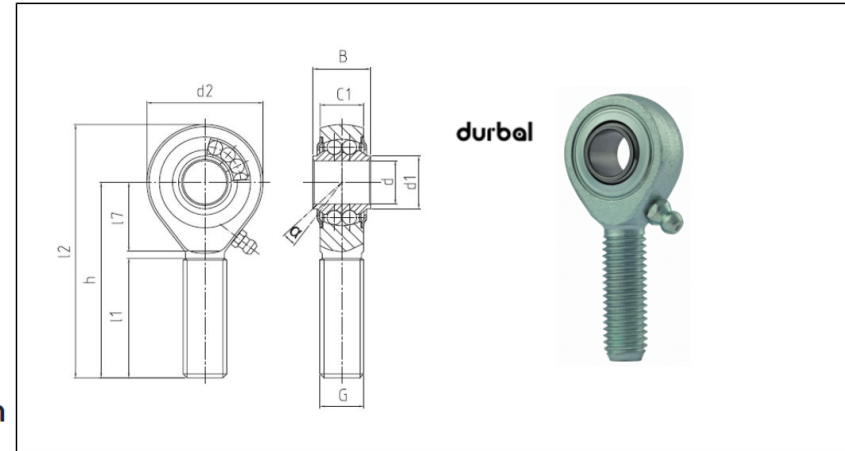

Type		Measurements [mm]															Tilt angle	Rotational speed limit	Axial factor		Basic load rating		Radial clearance	Weight
Right hand thread	Left hand thread	d	G	B	C1	h/h1	d1	d2	d3	d4	dk	l1/l3	l2/l4	l5	l7	W	α (°)	n_{max} (min ⁻¹)	Y	Y0	dyn C (kN)	stat C0 (kN)	CN (µm)	kg
BRM 06 - 00 - 501	BRM 06 - 00 - 502	6	M6	9	6.8	36	9	20	-	-	-	22	46	-	12	-	8	1350	2.09	2.19	2.8	0.7	10-30	0.02
BRM 08 - 00 - 501	BRM 08 - 00 - 502	8	M8	12	9	42	10.4	24	-	-	-	25	54	-	15	-	8.5	1300	1.8	1.89	4	1	10-30	0.04
BRM 10 - 00 - 501	BRM 10 - 00 - 502	10	M10	14	10.5	48	12.7	28	-	-	-	29	62	-	15	-	8	1225	1.9	1.81	4.5	1.5	10-30	0.06
BRM 12 - 00 - 501	BRM 12 - 00 - 502	12	M12	16	12	54	14.6	32	-	-	-	33	70	-	19	-	7.5	1125	1.74	1.82	5	1.8	10-30	0.09
BRM 14 - 00 - 501	BRM 14 - 00 - 502	14	M14	19	13.5	60	17.3	36	-	-	-	36	78	-	20	-	6	1025	2.36	2.48	5.6	2	10-30	0.14
BRM 16 - 00 - 501	BRM 16 - 00 - 502	16	M16	21	15	66	19	42	-	-	-	40	87	-	22	-	8	975	2.24	2.35	6.3	2.4	10-30	0.19
BRM 18 - 00 - 501	BRM 18 - 00 - 502	18	M18x1.5	23	16.5	72	21.9	46	-	-	-	44	95	-	25	-	8.5	900	2.21	2.31	7.1	2.9	10-30	0.27
BRM 20 - 00 - 501	BRM 20 - 00 - 502	20	M20x1.5	25	18	78	24.3	50	-	-	-	47	103	-	28	-	7	825	2.46	2.58	7.9	3.5	10-30	0.34
BRM 22 - 00 - 501	BRM 22 - 00 - 502	22	M22x1.5	28	20	84	25.8	54	-	-	-	51	111	-	26	-	8	725	2.35	2.24	9.3	4	10-30	0.45
BRM 25 - 00 - 501	BRM 25 - 00 - 502	25	M24x2	31	22	94	30.1	64	-	-	-	57	126	-	30	-	5	600	2.02	2.12	11	5.7	10-30	0.6
BRM 30 - 00 - 501	BRM 30 - 00 - 502	30	M30x2	37	25	110	34.5	70	-	-	-	66	145	-	35	-	7.5	450	2.24	2.35	14.2	7.5	10-30	0.92
BRM 35 - 00 - 501	BRM 35 - 00 - 502	35	M36x3	48	35	137	44.5	92	-	-	-	82	183	-	48	-	7	400	1.97	2.07	23.4	11.2	10-30	2
BRM 40 - 00 - 501	BRM 40 - 00 - 502	40	M42x3	66	49	170	60	120	-	-	-	94	230	-	70	-	7	360	2.01	2.1	36.7	16.7	10-30	4.35