

EFN

Data sheet - rev. 1.0

Rod Ends - Classic Line

Rod ends with pressed spherical-plain bearing, female thread, series E/EH, DIN ISO 12240-4 & 8139, maintenance required

FEATURES AND ADVANTAGES

- **HOUSING:** C45 forged steel, tempered, surface galvanized, free of Cr VI
- **OUTER RING:** ball bearing steel, hardened, ground, phosphated, from size 15 with single split, oil groove and drill holes
- **JOINT BALL:** 100Cr6 ball bearing steel, hardened, ground, phosphated
- **MAINTENANCE:** maintenance required, oiled on delivery, initial lubrication by the user
- **GREASE NIPPLE:** DIN 3405 D1/A (sizes 15 to 17), DIN 71 412 H1 (sizes 20 to 70)
- **TEMPERATURE RANGE:** -40° C to +200° C
- **USE & MAINTENANCE :** [see this page](#)
- **STATIC LOAD SERVICE LIFE :** [see this page](#)
- **TOLERANCES :** [see this page](#)

COMPONENTS AND DIMENSIONS

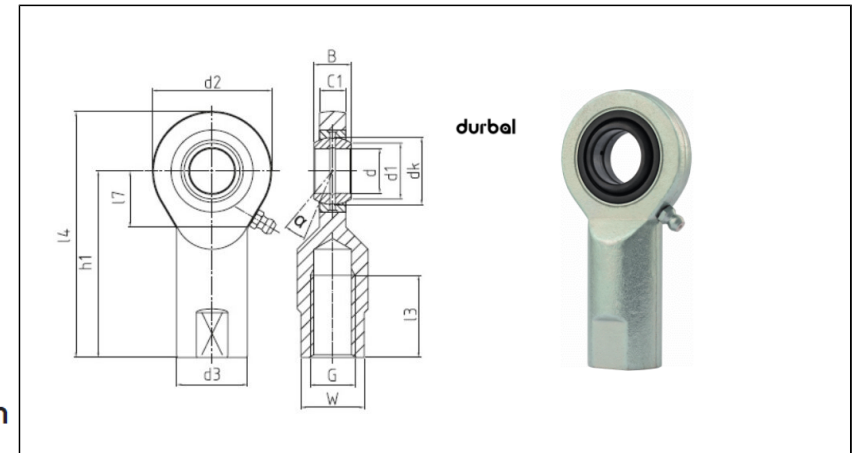

Type		Measurements [mm]															Tilt angle	Rotational speed limit	Axial factor		Basic load rating		Radial clearance	Weight
Right hand thread	Left hand thread	d	G	B	C1	h/h1	d1	d2	d3	dk	l1/l3	l2/l4	l5	l7	W	α (°)	n _{max} (min ⁻¹)	Y	Y0	dyn C (kN)	stat C0 (kN)	CN (µm)	kg	
EFN 06 - 20 - 501	EFN 06 - 20 - 502	6	M6	6	4	30	8	20	-	10	12	40	8.5	11	9	13	-	-	-	2.5	7.9	32-68	0.02	
EFN 08 - 20 - 501	EFN 08 - 20 - 502	8	M8	8	5	36	10	23	-	13	16	47.5	10.5	12	11	15	-	-	-	4.2	11.5	32-68	0.04	
EFN 10 - 20 - 501	EFN 10 - 20 - 502	10	M10	9	6	43	13	28	-	16	20	57	10.5	13	14	12	-	-	-	6.4	17.7	32-68	0.06	
EFN 10 - 21 - 501	EFN 10 - 21 - 502	10	M10x1.25	9	6	43	13	28	-	16	20	57	10.5	13	14	12	-	-	-	6.4	17.7	32-68	0.06	
EFN 12 - 20 - 501	EFN 12 - 20 - 502	12	M12	10	7	50	15	32	-	18	22	66	12.5	15	17	11	-	-	-	9.2	22.9	32-68	0.1	
EFN 12 - 21 - 501	EFN 12 - 21 - 502	12	M12x1.25	10	7	50	15	32	-	18	22	66	12.5	15	17	11	-	-	-	9.2	22.9	32-68	0.1	
EFN 15 - 20 - 501	EFN 15 - 20 - 502	15	M14	12	9	61	18	38	-	22	25	80	12.5	18	19	8	-	-	-	13.4	35.2	40-82	0.18	
-	EFN 15 - 30 - 502	15	M14	12	9	61	18	38	-	22	25	80	12.5	18	19	8	-	-	-	13.4	35.2	40-82	0.18	
EFN 17 - 20 - 501	EFN 17 - 20 - 502	17	M16	14	10	67	20	44	-	25	28	89	16.5	20	22	10	-	-	-	19.2	38.1	40-82	0.22	
EFN 17 - 21 - 501	EFN 17 - 21 - 502	17	M16x1.5	14	10	67	20	44	-	25	28	89	16.5	20	22	10	-	-	-	19.2	38.1	40-82	0.22	
EFN 20 - 20 - 501	EFN 20 - 20 - 502	20	M20x1.5	16	12	77	24	51	-	29	33	102.5	17.5	23	24	9	-	-	-	25.2	52.2	40-82	0.35	
EFN 25 - 20 - 501	EFN 25 - 20 - 502	25	M24x2	20	16	94	29	62	-	35.5	42	125	19.5	30	30	7	-	-	-	42.4	86.5	30-100	0.64	
EFN 30 - 20 - 501	EFN 30 - 20 - 502	30	M30x2	22	18	110	34	70	-	40.7	51	145	19.5	32	36	6	-	-	-	54	112	30-100	0.93	
EFN 35 - 20 - 501	EFN 35 - 20 - 502	35	M36x3	25	20	125	39	82	-	47	61	166	24.5	38	41	6	-	-	-	70.4	146.6	30-100	1.3	
EFN 35 - 21 - 501	EFN 35 - 21 - 502	35	M36x2	25	20	130	39	82	-	47	66	171	24.5	38	41	6	-	-	-	70.4	146.6	30-100	1.3	
EFN 40 - 21 - 501	EFN 40 - 21 - 502	40	M39x3	28	22	142	45	92	-	53	66	188	24.5	42	46	7	-	-	-	86	179.4	40-120	1.8	
EFN 40 - 20 - 501	EFN 40 - 20 - 502	40	M42x3	28	22	145	45	92	-	53	71	191	24.5	42	50	7	-	-	-	86	179.4	40-120	2	
EFN 45 - 20 - 501	EFN 45 - 20 - 502	45	M45x3	32	25	165	50	102	-	60	76	216	29.5	50	55	7	-	-	-	107	230.8	40-120	2.5	
EFN 45 - 21 - 501	EFN 45 - 21 - 502	45	M42x3	32	25	145	50	102	-	60	66	196	29.5	50	50	7	-	-	-	107	230.8	40-120	1.9	
EFN 50 - 21 - 501	EFN 50 - 21 - 502	50	M45x3	35	28	160	55	112	-	66	69	216	30.5	60	55	6	-	-	-	132	280.8	40-120	3	
EFN 50 - 20 - 501	EFN 50 - 20 - 502	50	M52x3	35	28	195	55	112	-	66	89	251	30.5	60	60	6	-	-	-	132	280.8	40-120	3.5	

Type		Measurements [mm]															Tilt angle	Rotational speed limit	Axial factor		Basic load rating		Radial clearance	Weight
Right hand thread	Left hand thread	d	G	B	C1	h/h1	d1	d2	d3	dk	l1/l3	l2/l4	l5	l7	W	α (°)	n_{max} (min ⁻¹)	Y	Y0	dyn C (kN)	stat C0 (kN)	CN (μ m)	kg	
EFN 60 - 20 - 501	EFN 60 - 20 - 502	60	M60x4	44	36	225	66	135	-	80	103	292.5	33.5	70	70	6	-	-	-	208	437.3	40-120	5.5	
EFN 60 - 21 - 501	EFN 60 - 21 - 502	60	M52x3	44	36	175	66	135	-	80	71	242.5	33.5	70	60	6	-	-	-	208	437.3	40-120	4	
EFN 70 - 21 - 501	EFN 70 - 21 - 502	70	M56x4	49	40	200	77	162	-	92	56	281	35	88	70	6	-	-	-	315	619.8	72-142	8	
EFN 70 - 20 - 501	EFN 70 - 20 - 502	70	M72x4	49	40	265	77	162	-	92	72	346	35	88	80	6	-	-	-	315	619.8	72-142	11	

ROTATIONAL UNITS