

BEF

Data sheet - rev. 1.0

Rod Ends - Classic Line

Rod ends with DURBAL-Glide (PTFE), female thread, series K, DIN ISO 12240-4 & 8139, maintenance free

FEATURES AND ADVANTAGES

- **HOUSING:** 17Cr3 forged steel, tempered, surface galvanized, free of Cr VI
- **RACE DURBAL-GLIDE:** Polyamid-PTFE-fibreglass-Compound
- **JOINT BALL:** 100Cr6 ball bearing steel, hardened, ground, polished and hard chromium plated
- **MAINTENANCE:** maintenance free
- **TEMPERATURE RANGE:** -30° C to +60° C
- **USE & MAINTENANCE :** [see this page](#)
- **STATIC LOAD SERVICE LIFE :** [see this page](#)
- **TOLERANCES :** [see this page](#)

COMPONENTS AND DIMENSIONS

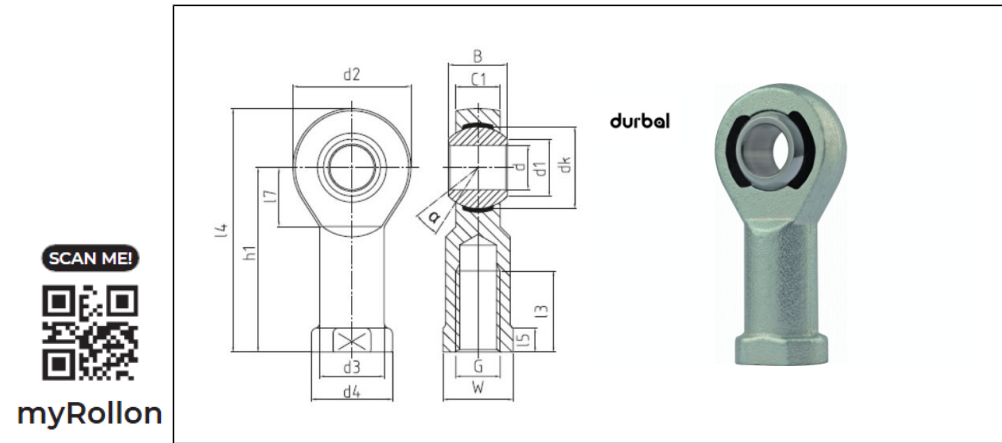

Type		Measurements [mm]															Tilt angle	Rotational speed limit	Axial factor		Basic load rating		Radial clearance	Weight
Right hand thread	Left hand thread	d	G	B	C1	h/h1	d1	d2	d3	d4	dk	l1/3	l2/4	l5	l7	W	α (°)	n _{max} (min ⁻¹)	Y	Y0	dyn C (kN)	stat C0 (kN)	CN (µm)	kg
BEF 05 - 20 - 501	BEF 05 - 20 - 502	5	M5	8	6	27	7.7	18	9	11	11.06	10	36	4	10	9	13	-	-	-	3.9	14.8	0-10	0.02
BEF 05 - 21 - 501	BEF 05 - 21 - 502	5	M4	8	6	27	7.7	18	9	11	11.06	10	36	4	10	9	13	-	-	-	3.9	14.8	0-10	0.02
BEF 06 - 20 - 501	BEF 06 - 20 - 502	6	M6	9	6.75	30	8.9	20	10	13	12.65	12	40	5	10	11	13	-	-	-	4.6	18.6	0-10	0.02
BEF 08 - 20 - 501	BEF 08 - 20 - 502	8	M8	12	9	36	10.3	24	12.5	16	15.82	16	48	5	12	14	14.5	-	-	-	7	25.4	0-10	0.05
BEF 10 - 20 - 501	BEF 10 - 20 - 502	10	M10	14	10.5	43	12.9	28	15	19	19	20	57	6.5	15	17	13.5	-	-	-	10.4	35.6	0-10	0.07
BEF 10 - 21 - 501	BEF 10 - 21 - 502	10	M10x1.25	14	10.5	43	12.9	28	15	19	19	20	57	6.5	15	17	13.5	-	-	-	10.4	35.6	0-10	0.07
BEF 12 - 21 - 501	BEF 12 - 21 - 502	12	M12x1.25	16	12	50	15.4	32	17.5	22	22.17	22	66	6.5	16	19	13	-	-	-	12.4	42.7	0-10	0.11
BEF 12 - 20 - 501	BEF 12 - 20 - 502	12	M12	16	12	50	15.4	32	17.5	22	22.17	22	66	6.5	16	19	13	-	-	-	12.4	42.7	0-10	0.11
BEF 14 - 20 - 501	BEF 14 - 20 - 502	14	M14	19	13.5	57	16.8	36	20	25	25.35	25	75	8	20	22	16	-	-	-	15.4	43.5	0-10	0.16
BEF 16 - 20 - 501	BEF 16 - 20 - 502	16	M16	21	15	64	19.3	42	22	27	28.52	28	85	8	22	22	15.5	-	-	-	22.4	62.3	0-10	0.23
BEF 16 - 21 - 501	BEF 16 - 21 - 502	16	M16x1.5	21	15	64	19.3	42	22	27	28.52	28	85	8	22	22	15.5	-	-	-	22.4	62.3	0-10	0.23
BEF 18 - 20 - 501	BEF 18 - 20 - 502	18	M18x1.5	23	16.5	71	21.8	46	25	31	31.7	32	94	10	24	27	15	-	-	-	26.3	72.7	0-10	0.31
BEF 20 - 20 - 501	BEF 20 - 20 - 502	20	M20x1.5	25	18	77	24.3	50	27.5	34	34.87	33	102	10	26	30	14.5	-	-	-	30.8	85	0-10	0.39
BEF 22 - 20 - 501	BEF 22 - 20 - 502	22	M22x1.5	28	20	84	25.8	54	30	38	38.05	37	111	12	26	32	15.5	-	-	-	38.2	98.9	0-10	0.52
BEF 25 - 20 - 501	BEF 25 - 20 - 502	25	M24x2	31	22	94	29.5	60	33.5	42	42.8	42	124	12	30	36	15	-	-	-	45.4	120.6	0-10	0.71
BEF 30 - 21 - 501	BEF 30 - 21 - 502	30	M27x2	37	25	110	34.8	70	40	50	50.75	51	145	15	35	41	17	-	-	-	55	149	0-10	1.08
BEF 30 - 20 - 501	BEF 30 - 20 - 502	30	M30x2	37	25	110	34.8	70	40	50	50.75	51	145	15	35	41	17	-	-	-	55	149	0-10	1.08