

BRTM Niro VR

Data sheet - rev. 1.0

Rod Ends - Premium Line Stainless Steel

Rod ends in stainless steel with roller bearing, full complement design, male thread, series K, DIN ISO 12240-4, low maintenance, lubrication possible

FEATURES AND ADVANTAGES

- **HOUSING:** AISI 420 stainless steel, forged, hardened, bearing race superfinished, size 18, 22, 25, 30 can be made as turning part, surface electropolished
- **INNER RING:** AISI 440b stainless steel, hardened, superfinished
- **ROLLING ELEMENT:** AISI 440c stainless steel, hardened, super
- **MAINTENANCE:** low maintenance, lubrication possible, aluminium-complex-soap-grease, approval according to USDA H1
- **GREASE NIPPLE IN STAINLESS STEEL:** DIN 3405 D1/A (until size 10) / DIN 71 412 H1 (from size 12), further grease nipples
- **TEMPERATURE RANGE:** -45° C to +120° C
- **USE & MAINTENANCE :** [see this page](#)
- **STATIC LOAD SERVICE LIFE :** [see this page](#)
- **TOLERANCES :** [see this page](#)

COMPONENTS AND DIMENSIONS

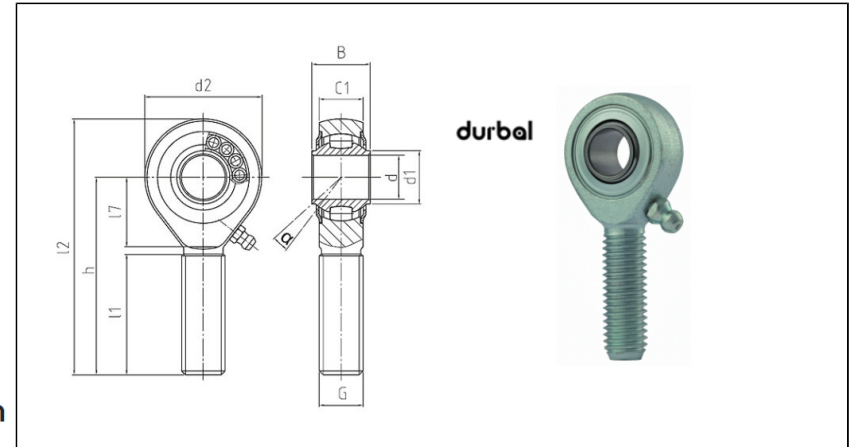

Type		Measurements [mm]															Tilt angle	Rotational speed limit	Axial factor		Basic load rating		Radial clearance	Weight
Right hand thread	Left hand thread	d	G	B	C1	h/h1	d1	d2	d3	d4	dk	l1/l3	l2/l4	l5	l7	W	α (°)	n_{max} (min ⁻¹)	Y	Y0	dyn C (kN)	stat C0 (kN)	CN (μ m)	kg
BRTM 10 - 90 - 501	BRTM 10 - 90 - 502	10	M10	14	10.5	48	12.7	28	-	-	-	29	62	-	15	-	8	820	9.5	5	8	4.6	10-30	0.08
BRTM 12 - 90 - 501	BRTM 12 - 90 - 502	12	M12	16	12	54	14.6	32	-	-	-	33	70	-	19	-	7.5	750	9.5	5	10.1	6.9	10-30	0.1
BRTM 16 - 90 - 501	BRTM 16 - 90 - 502	16	M16	21	15	66	19	42	-	-	-	40	87	-	22	-	7	650	9.5	5	12.1	8.3	10-30	0.21
BRTM 18 - 90 - 501	BRTM 18 - 90 - 502	18	M18x1.5	23	16.5	72	21.9	46	-	-	-	44	95	-	25	-	8.5	600	9.5	5	13	9	10-30	0.28
BRTM 20 - 90 - 501	BRTM 20 - 90 - 502	20	M20x1.5	25	18	78	24.3	50	-	-	-	47	103	-	28	-	7	550	9.5	5	14.4	10.1	10-30	0.37
BRTM 22 - 90 - 501	BRTM 22 - 90 - 502	22	M22x1.5	28	20	84	25.8	54	-	-	-	51	111	-	26	-	8	480	9.5	5	16.4	12.1	10-30	0.47
BRTM 25 - 90 - 501	BRTM 25 - 90 - 502	25	M24x2	31	22	94	30.1	64	-	-	-	57	126	-	30	-	5	400	9.5	5	18.7	14.4	10-30	0.64
BRTM 30 - 90 - 501	BRTM 30 - 90 - 502	30	M30x2	37	25	110	34.5	70	-	-	-	66	145	-	35	-	7.5	300	9.5	5	29.5	24.6	10-30	0.93

ROTATIONAL UNITS