

BRTF Zoll

Data sheet - rev. 1.0

Rod Ends - Premium Line

Rod ends with roller bearing, cage design, female thread, dimensions in inches, low maintenance, lubrication possible

FEATURES AND ADVANTAGES

- **HOUSING:** 17Cr3 forged steel, case hardened bearing race, superfinished, surface galvanized, free of Cr VI
- **INNER RING:** 100Cr6 ball bearing steel, hardened, superfinished
- **ROLLING ELEMENT:** 100Cr6 ball bearing steel, hardened, superfinished
- **MAINTENANCE:** low maintenance, lubrication possible, aluminium-complex-soap-grease, approval according to USDA H1
- **GREASE NIPPLE:** DIN 71 412 H1, further grease nipples
- **TEMPERATURE RANGE:** -45° C to +120° C
- **USE & MAINTENANCE :** [see this page](#)
- **STATIC LOAD SERVICE LIFE :** [see this page](#)
- **TOLERANCES :** [see this page](#)

COMPONENTS AND DIMENSIONS

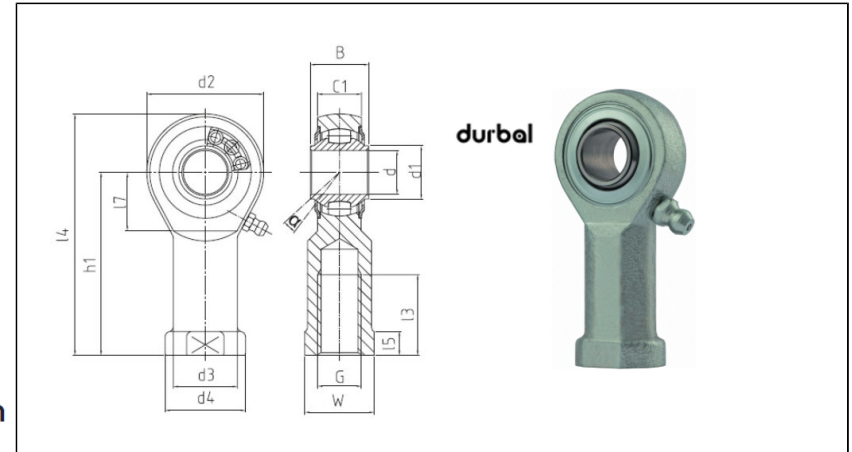

Type		Measurements [Inch]															Tilt angle	Rotational speed limit	Axial factor		Basic load rating		Radial clearance	Weight
Right hand thread	Left hand thread	d	G	B	C1	h/h1	d1	d2	d3	d4	dk	l1/l3	l2/l4	l5	l7	W	α (°)	n_{max} (min ⁻¹)	Y	Y0	dyn C (kN)	stat C0 (kN)	CN (µm)	kg
BRTF 1/2 - 00 - 501	BRTF 1/2 - 00 - 502	0.500	1/2 - 20 UNF	0.624	0.472	2.46	0.574	1.311	0.748	0.874	-	1.496	3.116	0.251	0.649	0.757	7	1125	9.5	5	10.3	6.6	10-30	0.13
BRTF 5/8 - 00 - 501	BRTF 5/8 - 00 - 502	0.625	5/8 - 18 UNF	0.826	0.59	2.618	0.748	1.635	0.866	1.063	-	1.574	3.444	0.35	0.885	0.866	7	975	9.5	5	13.3	8.9	10-30	0.22
BRTF 3/4 - 00 - 501	BRTF 3/4 - 00 - 502	0.750	3/4 - 16 UNF	0.984	0.708	3.09	0.956	1.968	1.082	1.338	-	1.85	4.074	0.409	1.043	1.181	7	825	9.5	5	16.7	11.5	10-30	0.39
BRTF 1/1 - 00 - 501	BRTF 1/1 - 00 - 502	1	1/1 - 12 UNF	1.22	0.866	3.72	1.161	2.519	1.171	1.377	-	2.244	4.98	0.236	1.279	1.181	5	600	9.5	5	24.9	18.5	10-30	0.57
BRTF 1/1 - 01 - 501	BRTF 1/1 - 01 - 502	1	1/1 - 14 UNS	1.22	0.866	3.72	1.161	2.519	1.171	1.377	-	2.244	4.98	0.236	1.279	1.181	5	600	9.5	5	24.9	18.5	10-30	0.57